

Alpha \$940,087

64' 4"

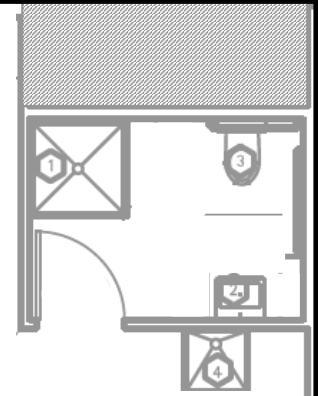

1st Floor: 64' 4" X 51'
3,063 SF

Mezzanine: 64' 4" X 13' - 14' 2" Clear
738 SF

Hangar Door: 57' 4" X 20'

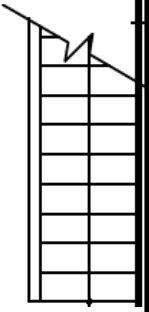

51'



51'

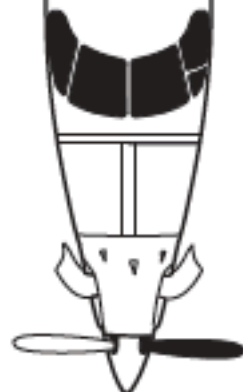

64' 4"

Bravo \$845,733

**1st Floor: 58' 4" X 51'
2,827 SF**

**Mezzanine: 58' 4" X 13'
14' 2" Clear
667 SF**

Hangar Door: 55' 2" X 20'

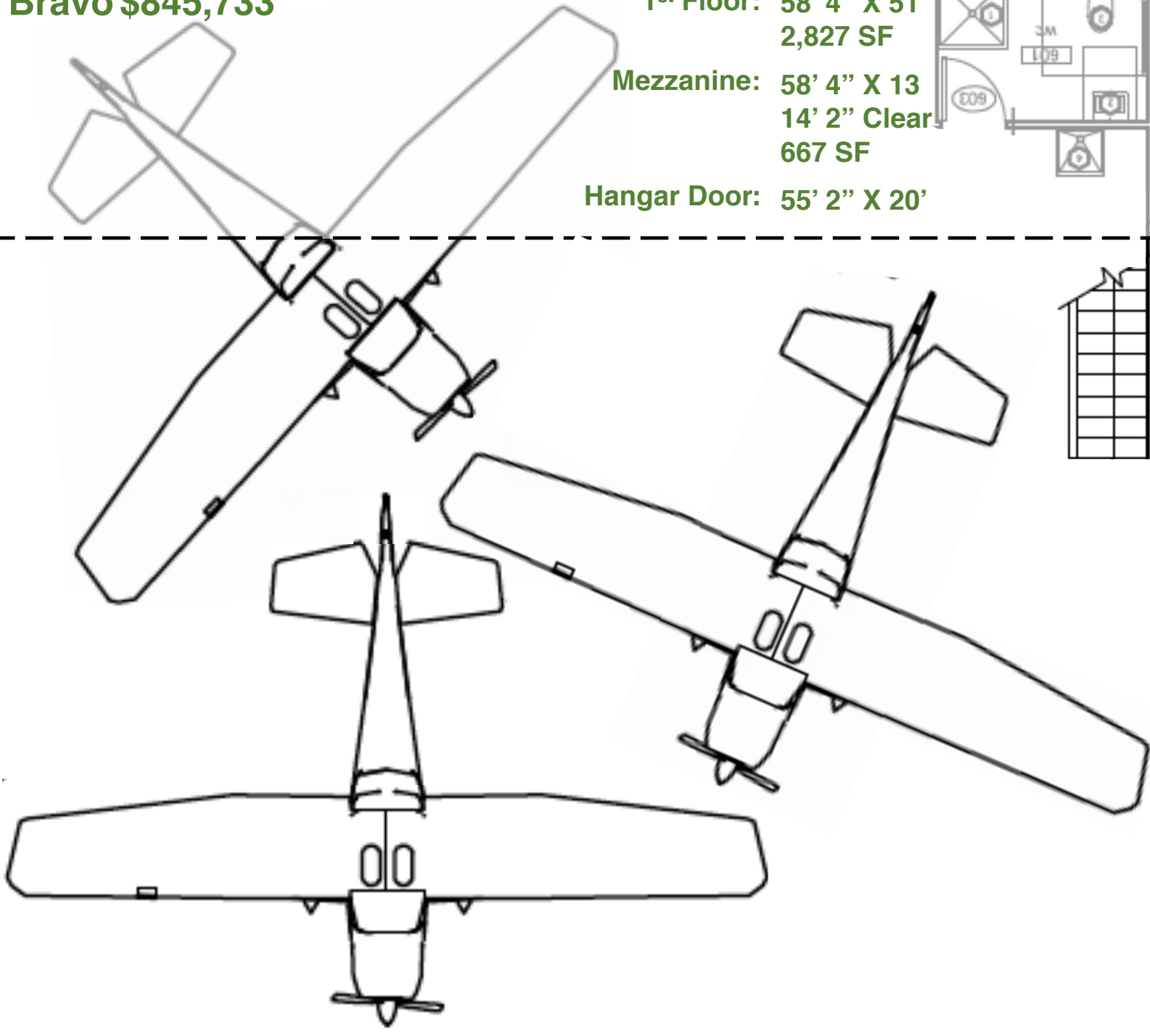
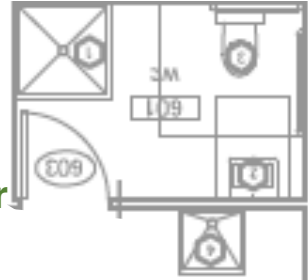

Charlie

\$986,262

68' 4"

**1st Floor: 68' 4" X 51'
3,232 SF**

**Mezzanine: 68' 4" X 13'
14' 2" Clear
790 SF**

Hangar Door: 60' 5" X 20'

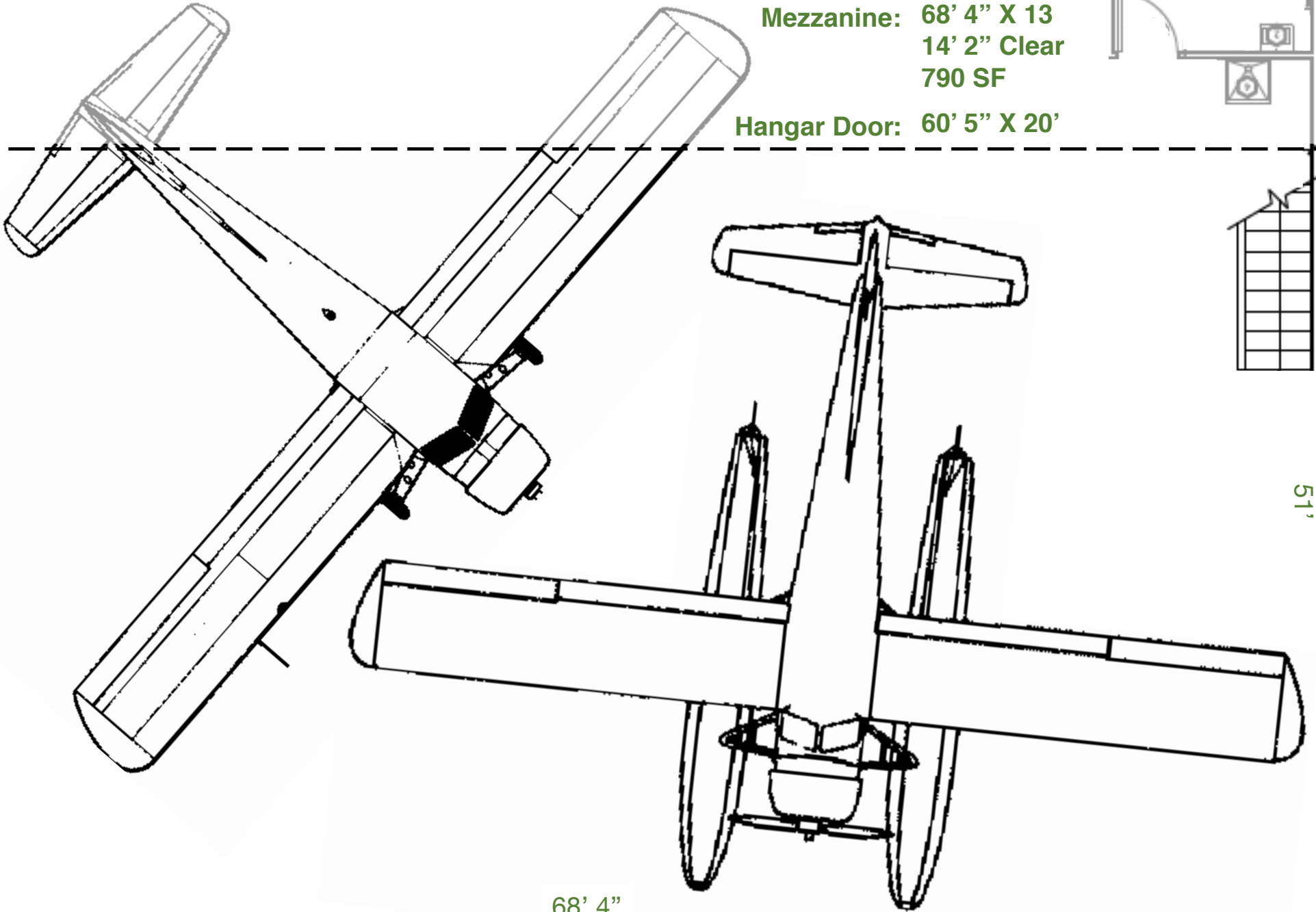
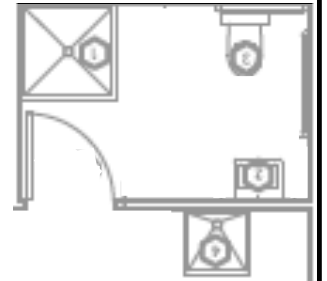

51'

51'

68' 4"

Delta \$1,831,995 (Combination of Bravo & Charlie)

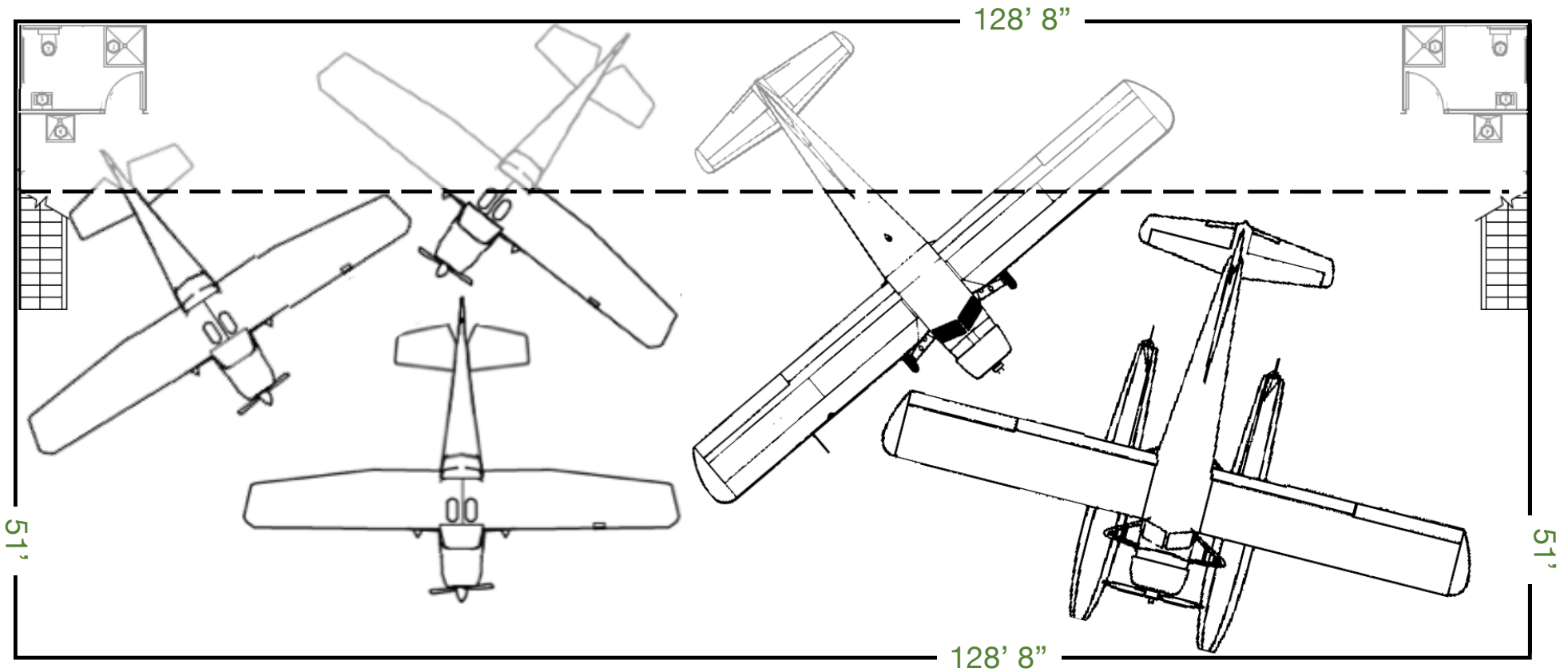

<u>1st Floor</u>	<u>Hangar Doors</u>	<u>Mezzanine</u>
126' 8" X 51	60' 5" X 20'	126' 8" X 51
6,059 SF	55' 2" X 20'	15' 14' 2" Clear
		1,457 SF

Echo \$1,330,335

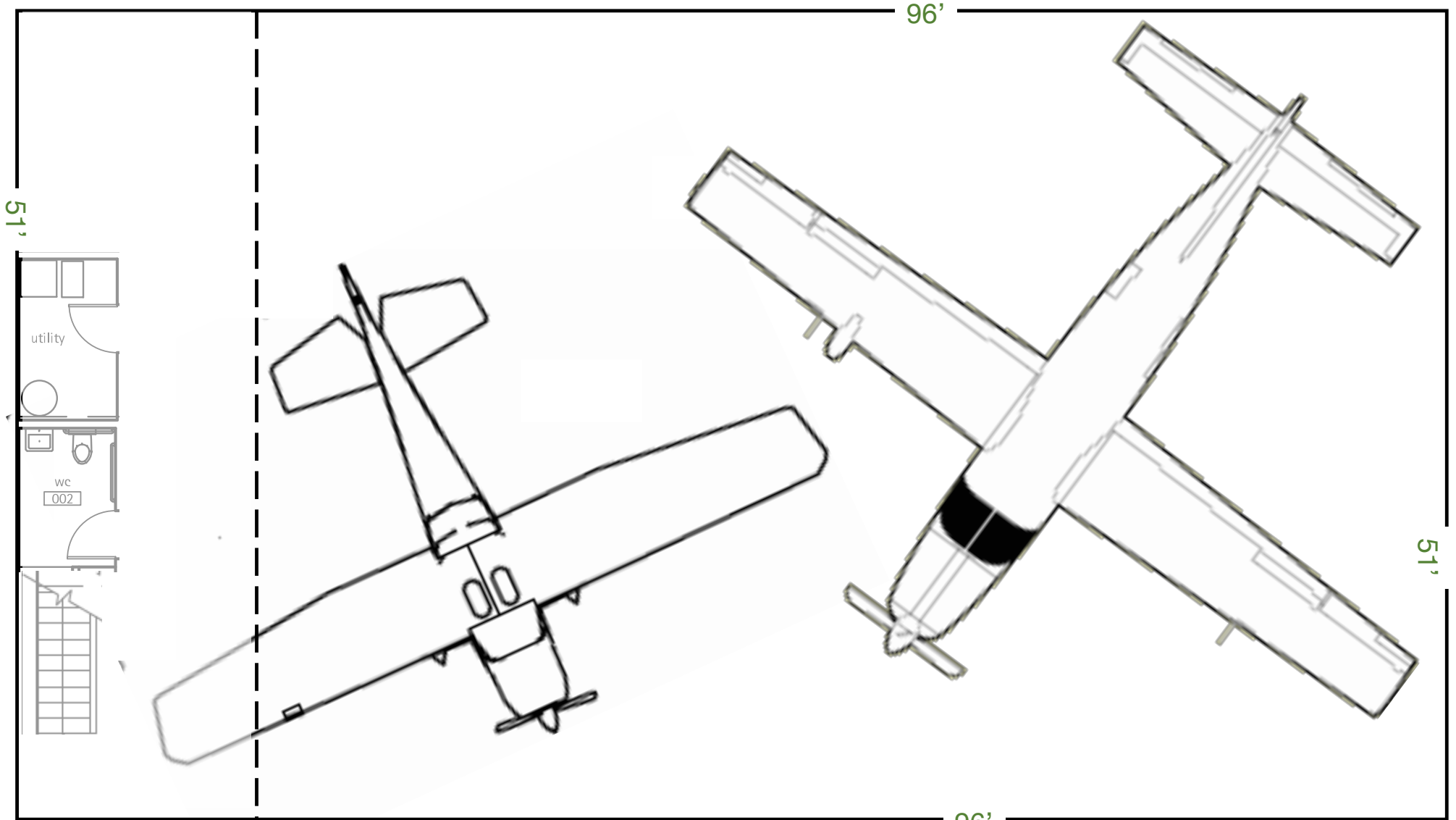

1st Floor

51' X 96"
4,896 SF

Hangar Door

70" X 21'

Mezzanine

15' X 51'
15' Clear
765 SF

Echo \$1.35/sf NNN Lease (\$7,642/mo)

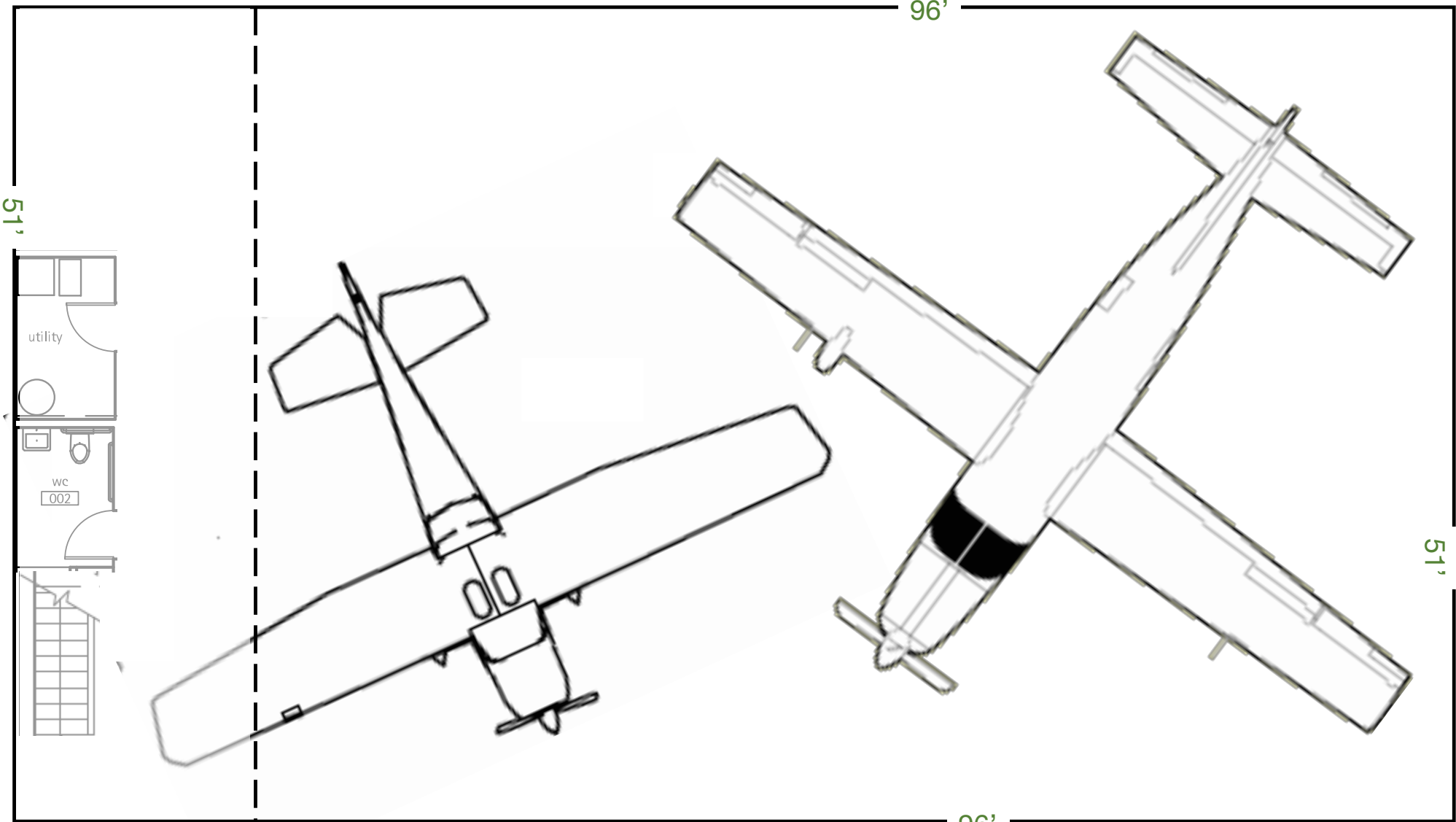

<u>1st Floor</u>	<u>Hangar Door</u>	<u>Mezzanine</u>
51' X 96"	70" X 21'	15' X 51'
4,896 SF		15' Clear 765 SF